

The TxIsoBlock transmitter is intended for in head mounting. Its drawing is presented in figure 3.

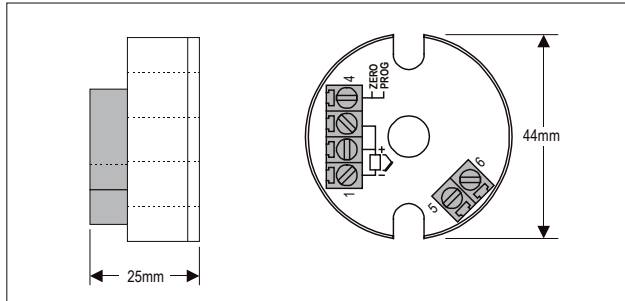

Figure 3 – TxIsoBlock dimensions

Electrical connections

Connector specification:

- Insulating material: Polyamide, self-extinguishing to UL 94, V-0;
- Connection wire cross section: 0,14-1,5 mm<sup>2</sup> / AWG 28-14;
- Screw tightening torque: 0,8 Nm / 7.0 lb-in;
- Terminal block: CuZn;

It is important to follow the recommendations below:

- Signal wires should be installed in grounded conduits and away from power or contactor wires.
- The instrument should have its own power supply wires, which should not be shared with electrical motors, coils, contactors, etc.
- Installing RC filters is strongly recommended at contactor coils or any other inductors.
- System failure should always be taken into account when designing a control panel to avoid irreversible damage to equipment or people.

Figure 4 below shows the TxIsoBlock connections to the sensor and power supply. Terminals 1, 2 e 3 are used for sensor input. For 2-wire Pt100, terminals 2 and 3 shall be connected together

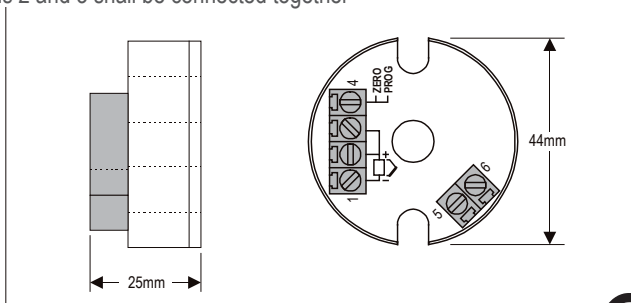

Figure 4 – TxIsoBlock wiring (Pt100)

Figure 5 below shows the thermocouple wiring.

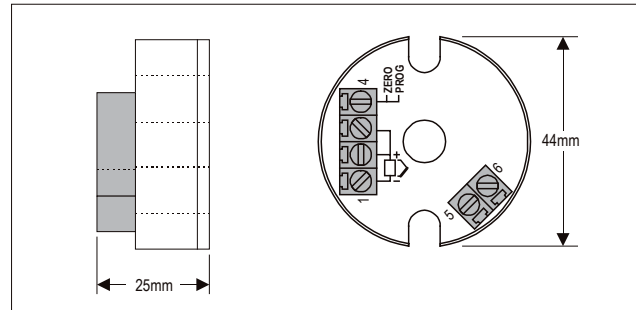

Figure 5 – TxIsoBlock wiring (Thermocouple)

The **LOAD** represents the input shunt of an instrument measuring the 4-20 current loop.

Operation

All input types and the 4-20mA output current are factory calibrated. However, a manual offset trim is implemented to provide fine adjustments to the signal in the field. This is accomplished by means of short circuiting terminals 4 (Zero) and 1(-). The transmitter waits 2 seconds before it starts changing the offset. The offset adjustment is capable of varying the output current by an amount equal to  $\pm 0.80\text{mA}$  relative to the original calibration. After reaching the maximum value ( $0.80\text{mA}$  above the original current), the output is driven instantly to  $-0.80\text{mA}$  below the original current, and continues increasing. When the desired output current (offset) is reached, opening the jumper will cause the TxIsoBlock to acknowledge the new offset value. Fine trimming is possible with momentary (2s minimum) jumper contact.

The offset correction can also be accomplished by the TxConfig software. See in Figure 3 the **Zero Correction** field for this purpose. The serial adaptor can be connected to the transmitter while it is operating in the process.

**Note:** when using a Pt100 simulator, make sure the TxIsoBlock Pt100 excitation current ( $0.18\text{mA}$ ) is compatible with the simulator specification.

The input types are listed in Table 1, along with the maximum and minimum ranges accepted by each one. The TxConfig software will allow only configurations that are consistent with the data in this table.

Please note that the specified accuracy is referenced to the maximum span of each input type. For instance, for the Pt100 input, the 0.2% accuracy results in  $1.7^\circ\text{C}$  total accuracy  $[(530 - (-200)) \times 0.2]$ .

# Installation and operating manual

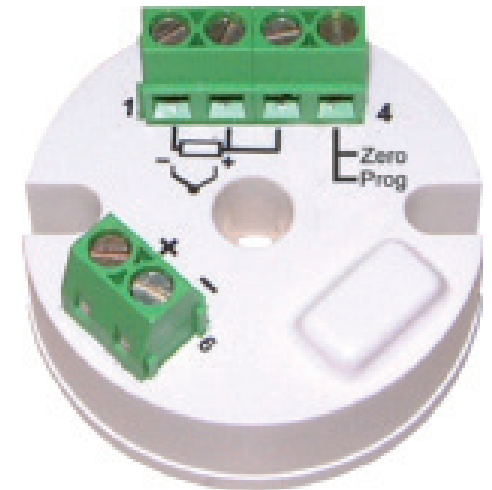

Microprocessor based isolated temperature transmitter

**TxIsoBlock**  
**0555 0034**



## Presentation

The TxIsoBlock is a 2-wire in-head temperature transmitter with galvanic isolation between input and output. Microprocessor based, it was designed for flexibility, accepting mV, Pt100 and a variety of thermocouples as the input sensor. The TxIsoBlock delivers a scalable linear 4-20mA output current proportional to the sensor temperature. A user-friendly configuration software is provided for parameter setup, including sensor type, temperature range, etc.

## Specifications

**Sensor input:** User defined. The supported sensors are listed in table 01, along with their maximum ranges.

**Thermocouples:** Types J, K, R, S, T, N, E and B to IEC 60584 (ITS-90). Impedance >> 1 MΩ

**Pt100:** Excitation: 180 μA., 2 or 3-wire connection (for 2-wire sensors, tie terminals 2 and 3 together). a= 0.00385, according to IEC 60751(ITS-90).

**Voltage:** 0 to 50 mVdc, 0 to 10 Vdc. Impedance >> 1M Ω.

Sensor type	Range	Minimum measurement span
Thermocouple K	-150 to 1370 °C	100 °C
Thermocouple J	-100 to 760 °C	100 °C
Thermocouple R	-50 to 1760 °C	400 °C
Thermocouple S	-50 to 1760 °C	400 °C
Thermocouple T	-160 to 400 °C	100 °C
Thermocouple N	-270 to 1300 °C	100 °C
Thermocouple E	-90 to 720 °C	100 °C
Thermocouple B	500 to 1820 °C	100 °C
Pt100	-200 to 600 °C	40 °C
Voltage	0 to 50 mV	5 mV

Table 1 – TxIsoBlock input sensors

**Output:** 2-wire 4-20 mA, linear with respect to the measured signal.

**Total accuracy:** better than 0,3 % of the maximum range for thermocouples and 0,2 % for Pt100 and voltage;

**Resolution:** 0,001mA (14 bits).

**Response Time:** < 500 ms;

**Power supply:** 12 to 35 VDC, across the transmitter;

**Maximum load (RL):**  $RL (max.) = (V_{cc} - 12) / 0,02 [W]$ , where:  $V_{cc}$ = Power supply voltage

**Operating Temperature:** -40 to 85 °C

**Humidity:** 0 a 90 % RH

**Electromagnetic compatibility:** EN 61326-1:2013 (2014/30/EU)

**Isolation:** 1000Vac for 1 minute between sensor input and the 4-20mA loop.

**Housing:** ABS plastic. Dimensions: 44mm (diameter) x 25mm (height).

**Internal protection against polarity inversion.**

**Cold junction compensation for thermocouples**

## Configurator

Please check the configuration parameters programmed in the TxIsoBlock, using the TxConfig software. A communication path needs to be established between the TxIsoBlock and the serial port of a PC. The 1.5m long TxConfig Adaptor is provided for this purpose. Connect its DB9 end to the PC COMM port and the other end to the transmitter as shown in Figure 1.

Once configured, the transmitter is ready to be installed in the process.

Note: The TxConfig Adaptor and Software can be purchased separately from or one of its distributors. The latest release of this software can be downloaded from our web site [www.com.br](http://www.com.br). Do not save the TxConfig software into a file which contains accent marks. To install, run the Tx\_setup.exe and follow the instructions. To install the configurator, run the Tx\_setup.exe file.

Serial port configuration errors may occur when other devices are sharing the same port (ex.: Palm Hot Sync). Close all serial port applications prior to using the TxConfig software.

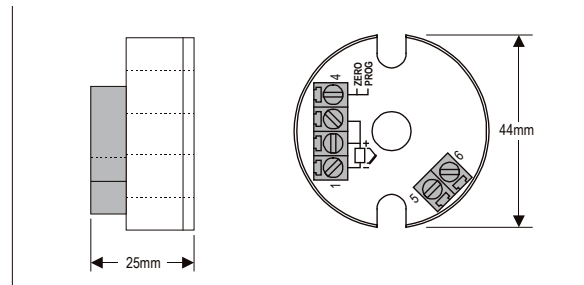

Figure 1 – Adaptor connections to the TxIsoBlock

The transmitter requires to be powered during the configuration. Depending on the PC used, the power can be supplied by the serial port. To assure proper communication, it is recommended to apply external power to the TxIsoBlock. The TxConfig Adaptor provides a 9V battery socket for powering the transmitter during the configuration. A jumper wire must be connected between terminals 1 and 6 during configuration when power is provided by the serial port or TxConfig battery. This jumper offends isolation and must be removed before installing the TxIsoBlock.

Do not use the battery if the transmitter is being powered by another supply or connected to the process, as in Figure 2.

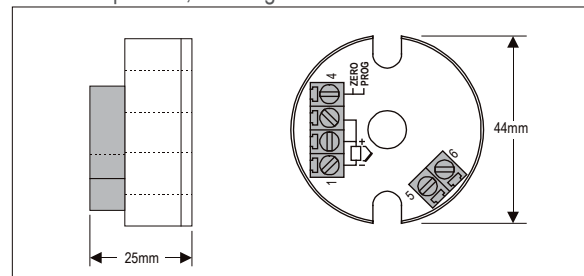

Figure 2 – TxIsoBlock-TxConfig Adaptor wiring (loop powered). Terminal 5 is left opened

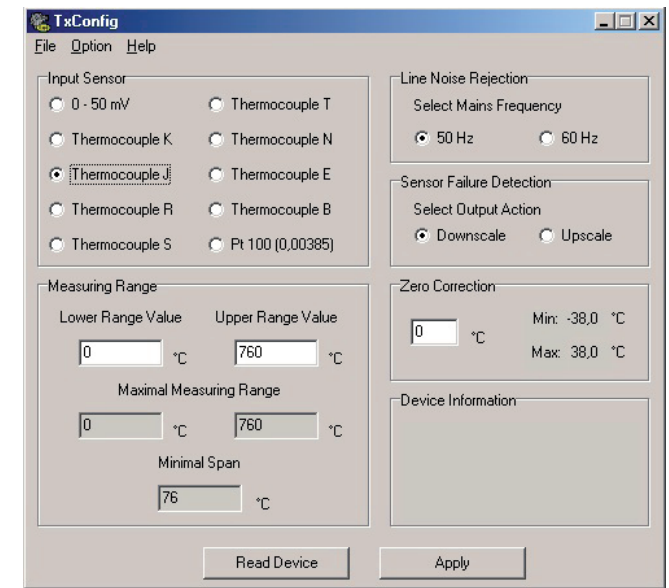

Figure 3 –TxConfig main screen

The fields in the screen mean:

1. **Input sensor:** Choose the desired temperature sensor among the available options.

2. **Measuring range:** Defines the beginning and the end of the range.

**Lower range value:** sets the value of the input signal (temperature or mV) associated to the 4 mA output.

**Upper range value:** sets the value of the input signal that will correspond to the 20 mA output

The values configured in these fields can not be beyond the sensor measuring range. The minimum span value has to be observed as well (see table 1).

3. **Line noise rejection:** The transmitter incorporates a digital filter to cancel the induced noise from the 50 or 60 Hz systems. For better performance, select the line frequency used in your country.

4. **Sensor failure detection:** establishes the transmitter output behavior (upscale or down-scale) in the presence of a sensor fail.

5. **Zero correction:** Allows for small sensor corrections.

6. **Read configuration:** Brings to the screen the current transmitter parameters configuration.

7. **Apply:** Sends a new configuration to the transmitter.

8. **Device information:** The device information box contains relevant data concerning a particular transmitter. Please pass along this information when contacting the technical assistance department.

**Note:** The factory default configuration is (unless otherwise specified or ordered):

- Pt100 input, 0 to 100 °C
- 60 Hz filtering and upscale (20 mA) output for sensor fail